

THIS COPY IS PROVIDED ON A RESTRICTED BASIS AND IS NOT TO BE USED IN ANY WAY DETRIMENTAL TO THE INTERESTS OF PANDUIT CORP.

Material	High Conductivity Seamless Copper Tube
Plating	Electro-Tin
Wire Size	4 STR/FLEX (ALL), 3 & 5 FLEX*
Wire Type	Stranded Copper: Class B & C, Compact, Class G, H, I, K, M, Locomotive (*Locomotive only)
Wire Strip Length	5/8 in.
Stud Size	3/8 in.
UL Listed Wire Connector	Yes, for applications up to 35kv. Consult cable manufacturer for voltage stress relief instructions with applications greater than 2000 volts.
UL Temperature Rating	90° C
C.S.A Certified Wire Connector	Yes
Panduit Color Code on Barrel	GRAY
Panduit Die Index No. on Barrel	P29
Alternate Industry Die Index No. () on Barrel	(8)

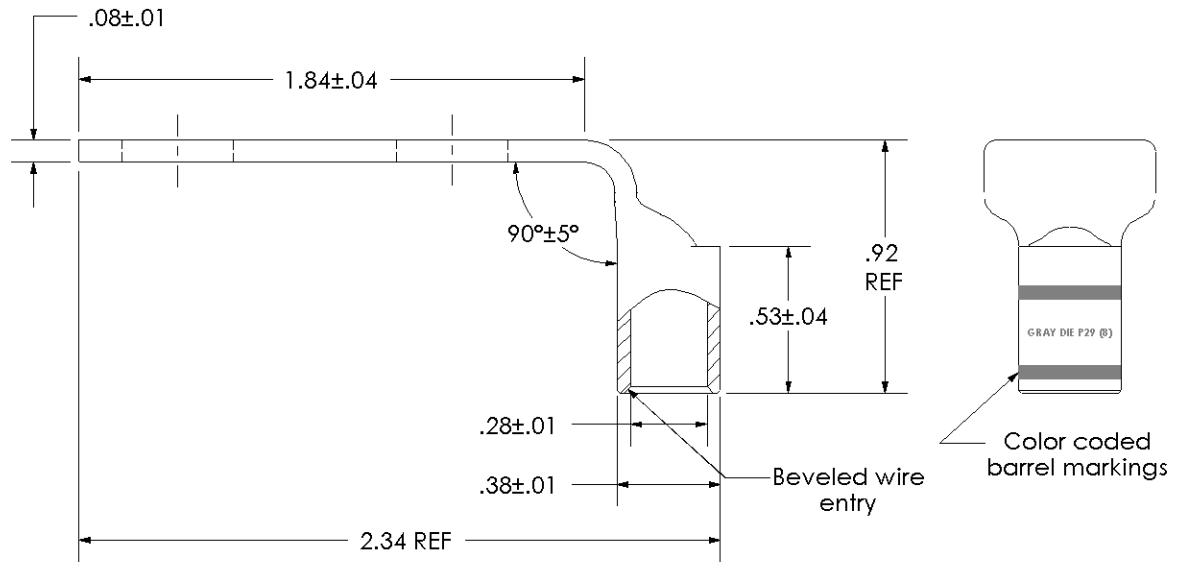
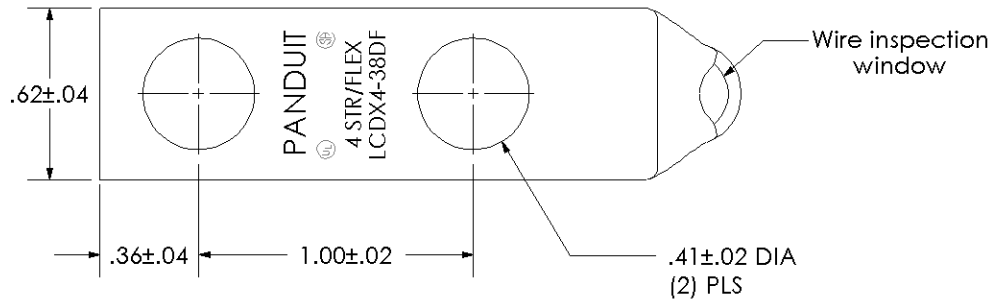

PANDUIT CORP. TINLEY PARK, ILLINOIS

LCDX4-38DF-L
Copper Lug - Two-Hole, Standard Flex Barrel, 90° Angle Tongue

01	3/04	KLFU	TLCO	WIRE SIZE WAS: 4 STR/FLEX ADDED 3 & 5 FLEX, LOCOMOTIVE ONLY * NOTE	11610
----	------	------	------	---	-------

REV	DATE	BY	CHK	DESCRIPTION	ECN	SCALE	DRAWING NO / CAD FILE
						N/A	LCDX4-38DF-CUST